

CIRCUIT DIAGRAM

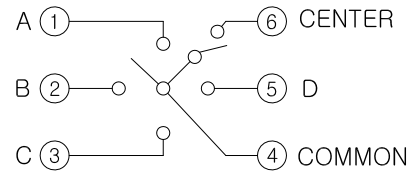

P.C.B LAND PATTERN

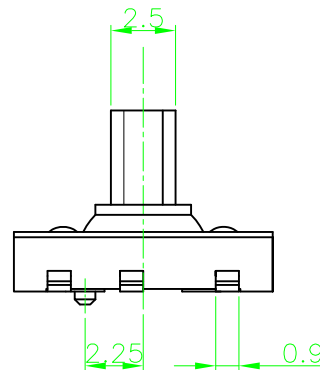

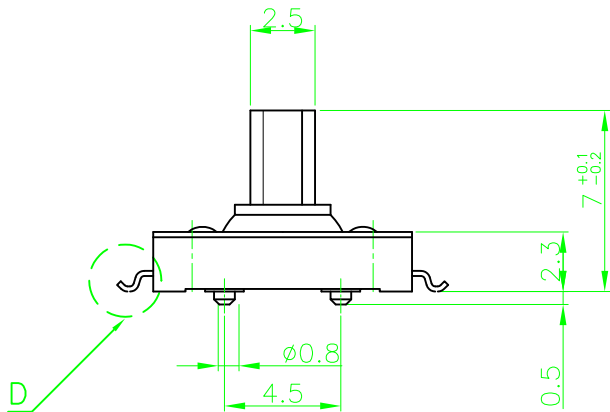
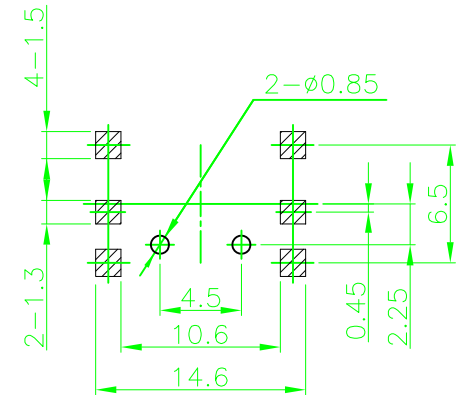

SPECIFICATION

1. RATING : 12V DC, 50mA Max.
2. STROKE : CENTER PUSH : 0.2±0.1
3. CONTACT RESISTANCE: 100mΩ Max.
4. OPERATING FORCE :
 4-DIRECTIONAL : 180±50gf
 CENTER PUSH : 320±70gf
5. OPERATING ANGLE : 4°±2°
6. BOUNCE : 10msec
7. LIFE : 100,000 CYCLES
8. TOLERANCE : ±0.2

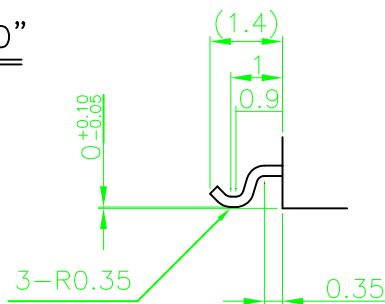
DETAIL "D"



									TS-V-046	
									TS-R-026	
PART NO.		MODEL		MATERIAL		SPECIFICATION		TREATMENT		REFERENCE
				TRIGONO-METRY		UNIT	SCALE	USER		TACT SWITCH
				APPROVAL		CHECK	DESIGN	TITLE		STF551SB
							J.W.CHOI	DWG NO.		
MARK		DATE		APPR.		CHECK		DESIGN		2006. 1. 16