

CIRCUIT DIAGRAM

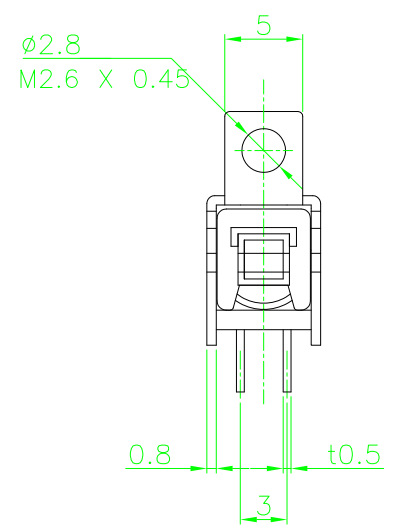
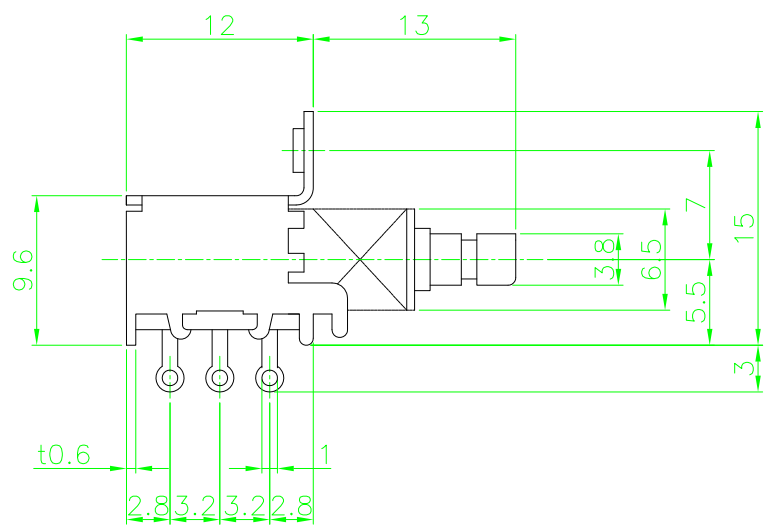
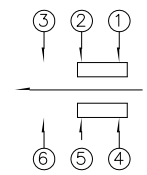
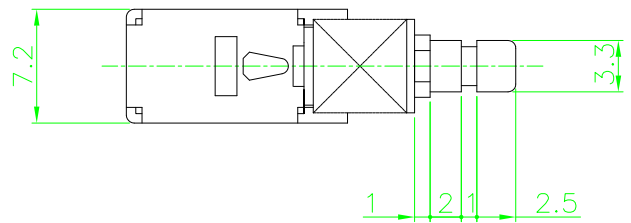

SPECIFICATION

1. RATING : 30V DC, 0.2A Max.
2. CIRCUIT : 2C- 2P
3. MECHANISM : SELF LOCK
4. TIMING : NON SHORTING
5. STROKE : FULL : 3.5
LOCK : 2.5
6. OPERATING FORCE : 300±100gf.
7. TOLERANCE : ±0.2

											PS-S-002
PART NO.		MODEL			MATERIAL		SPECIFICATION		TREATMENT	REFERENCE	
					TRIGONO -METRY	UNIT m/m	SCALE	USER	PUSH SWITCH		
					APPROVAL	CHECK	DESIGN	TITLE	PPL222LN-T		
							J.W. CHOI	DWG NO.			
MARK	DATE	APPR.	CHECK	DESIGN		2005.11.2					