

CIRCUIT DIAGRAM

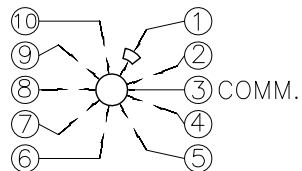

P.C.B LAND PATTERN

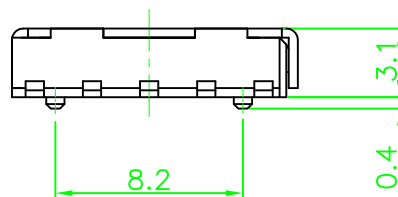
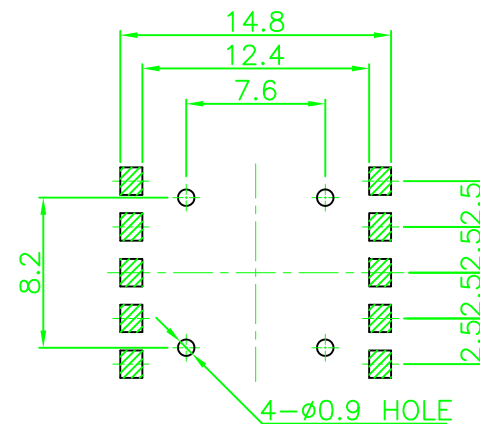

SPECIFICATION

1. RATING : 16V DC, 0.1A Max.
2. POLES-THROWS : 1C - 9P
3. STEP ANGLES : 40°
4. TIMING : NON SHORTING
5. ROTATIONAL TORQUE : 130±50gf.cm
6. CONTACT RESISTANCE : 50mΩ Max.
7. LIFE : 10,000 Cycles Min.
8. TOLERANCE : ±0.2

								TS-R-021		
								RS-V-01		
PART NO.		MODEL			MATERIAL		SPECIFICATION		TREATMENT	REFERENCE
					TRIGONOMETRY		UNIT	SCALE	ROTARY SWITCH	
							m/m	/	USER	
					APPROVAL		CHECK	DESIGN	TITLE	
							M.K. JUNG		SRS191NS	
MARK	DATE	APPR.	CHECK	DESIGN			2005.4.28	DWG NO.		