

STM151

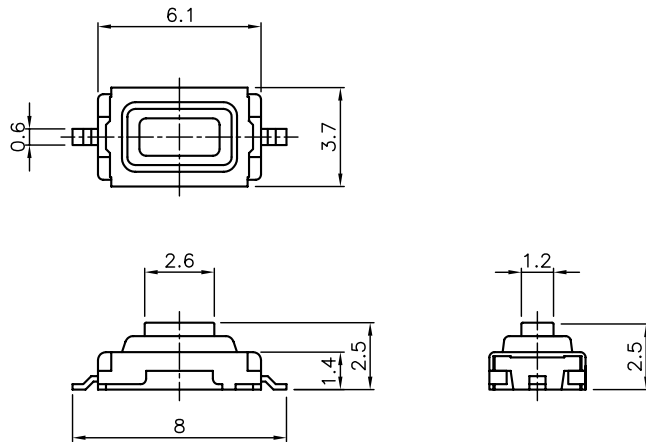

Description		Model	STM151NS	STM151JS	STM151SS	STM151HS
Operating Force (gf)			130±30	160±30	200±50	260±50
Stem Color			Black	Blue	Gray	Red
Life Cycle (min)			50,000	50,000	30,000	30,000
Rating (max)			50mA, 12V DC			
Stroke (mm)			0.25±0.1			
Contact Resistance			100 mΩ max			
Ground Terminal			With & Without			
Features			Dust proof, Thin type, Reflow soldering			
Packaging	Bulk		1,000 pcs / Bag			
	Reel		3,000 pcs / Reel			

P.C.B Layout

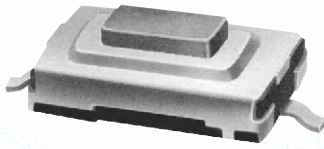
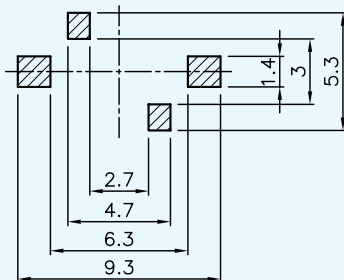

Circuit Diagram

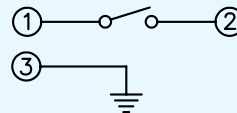

Tape Packaging

