

STM153

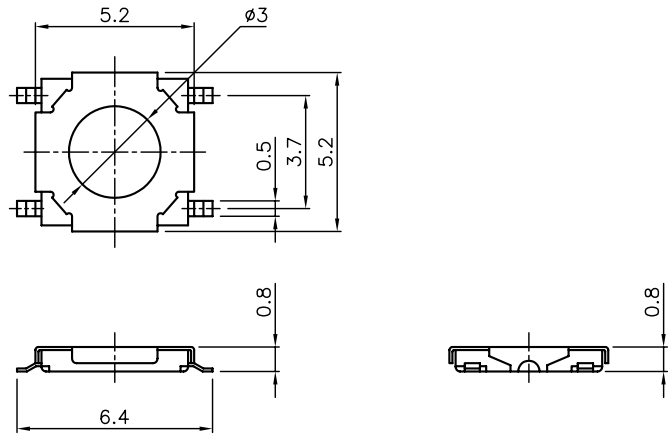

Description		Model	STM153JS-K	STM153JS	STM153HS
Operating Force (gf)			160±30	160±30	260±50
Case Color			Gray	Ivory	Black
Life Cycle (min)			1,000,000	300,000	100,000
Rating (max)			50mA, 12V DC		
Stroke (mm)			0.25±0.1		
Contact Resistance			100 mΩ max		
Features			Long life, Dust proof, Thin type, Reflow soldering		
Packaging	Bulk		1,000 pcs / Bag		
	Reel		3,000 pcs / Reel		

P.C.B Layout

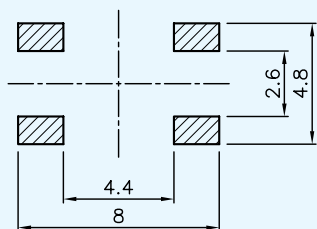

Circuit Diagram

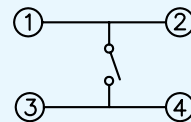

Tape Packaging

