

CIRCUIT DIAGRAM

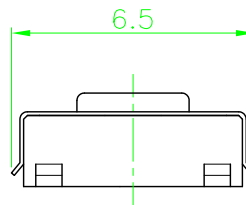

P.C.B. LAND PATTERN

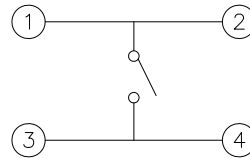
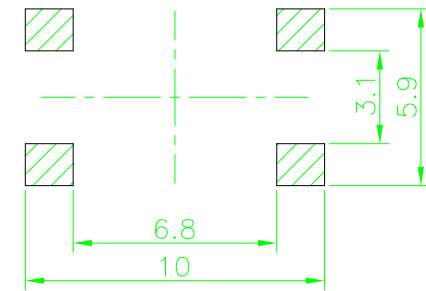

SPECIFICATION

1. RATING : 12V DC, 50mA Max.
2. STROKE : 0.25±0.1
3. CONTACT RESISTANCE : 100mΩ Max.
4. OPERATING FORCE : 130±30gf.
5. BOUNCE : 5msec Max.
6. LIFE : 300,000 Cycles Min.
7. TOLERANCE : ±0.2

									TS-V-040	
									TS-R-024	
PART NO.		MODEL		MATERIAL		SPECIFICATION		TREATMENT		REFERENCE
						TRIGONO-METRY		UNIT		SCALE
						APPROVAL		CHECK		DESIGN
								M. K. JUNG		USER
								2005.4.11		TITLE
MARK		DATE		APPR.		CHECK		DESIGN		DWG NO.