

CIRCUIT DIAGRAM

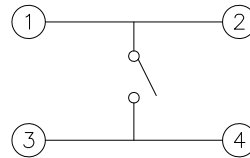

P.C.B. LAND PATTERN

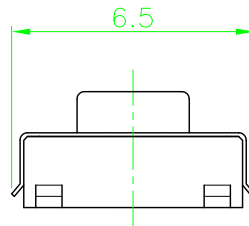
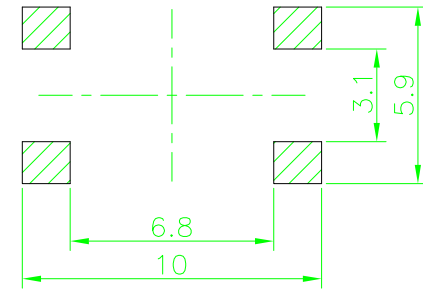

SPECIFICATION

1. RATING : 12V DC, 50mA Max.
2. STROKE : 0.25±0.1
3. CONTACT RESISTANCE : 100mΩ Max.
4. OPERATING FORCE : 200±50gf.
5. BOUNCE : 5msec Max.
6. LIFE : 100,000 Cycles Min.
7. TOLERANCE : ±0.2

									TS-V-042	
									TS-R-024	
PART NO.		MODEL		MATERIAL		SPECIFICATION		TREATMENT		REFERENCE
				TRIGONO-METRY		UNIT	SCALE	USER		TACT SWITCH
				APPROVAL		m/m	DESIGN	TITLE		STM255SX
						CHECK	M. K. JUNG	DWG NO.		
MARK	DATE	APPR.	CHECK			DESIGN	2005.4.11			