

CIRCUIT DIAGRAM

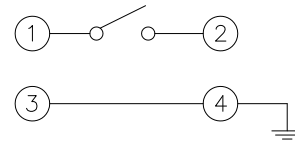

P.C.B MOUNTING HOLE

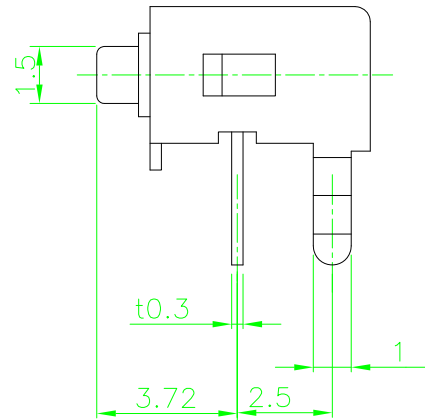
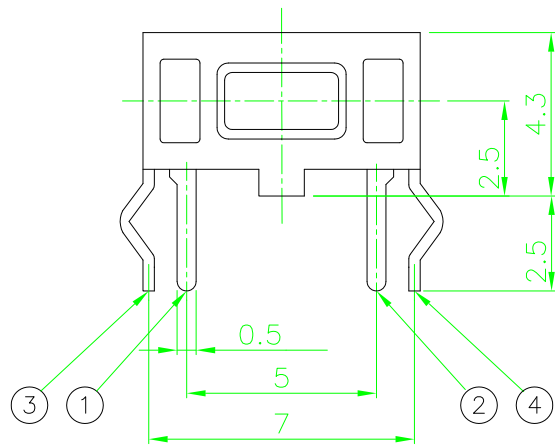
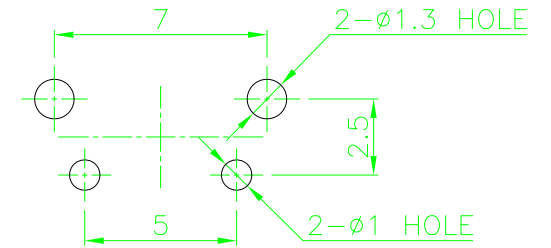

SPECIFICATION

1. RATING : 12V DC, 50mA Max.
2. STROKE : 0.25±0.1
3. CONTACT RESISTANCE : 100mΩ Max.
4. OPERATING FORCE : 200±50gf.
5. BOUNCE : 10msec Max.
6. LIFE : 30,000 Cycles Min.
7. TOLERANCE : ±0.2

											TS-V-006
PART NO.		MODEL			MATERIAL		SPECIFICATION		TREATMENT	REFERENCE	
					TRIGONO	UNIT	SCALE	USER		TACT SWITCH	
					-METRY	m/m					
					APPROVAL	CHECK	DESIGN	TITLE		PTH117SF	
						M.K. JUNG	J.W. CHOI				
MARK	DATE	APPR.	CHECK	DESIGN		2005.5. 4	2005.5. 4	DWG NO.			